

# Important topic for DTM 4th semester examination

## IN/OUT Interface

### Introduction:

Any application of a microprocessor based system requires the transfer of data between external circuitry to the microprocessor and microprocessor to the external circuitry. User can give information to the microprocessor based system using keyboard and user can see the result or output information from the microprocessor based system with the help of display device. The transfer of data between keyboard and microprocessor, and microprocessor and display device is called input/output data transfer or I/O data transfer. This data transfer is done with the help of I/O ports.

### Input port:

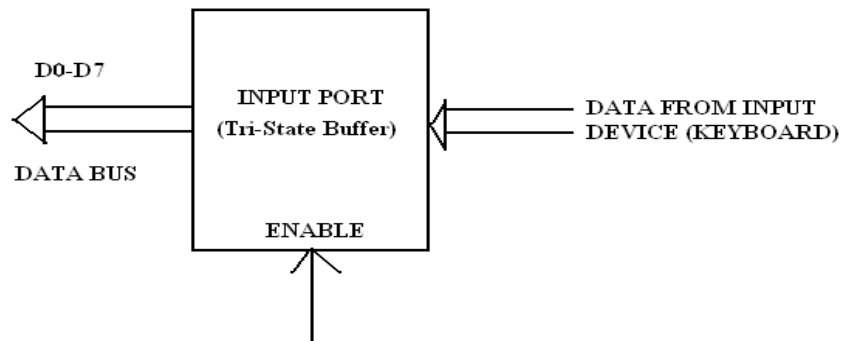

FIG.1 INPUT PORT

It is used to read data from the input device such as keyboard. The simplest form of input port is a buffer. The input device is connected to the microprocessor through buffer, as shown in the fig.1. This buffer is a tri-state buffer and its output is available only when enable signal is active. When microprocessor wants to read data from the input device (keyboard), the control signals from the microprocessor activates the buffer by asserting enable input of the buffer. Once the buffer is enabled, data from the input device is available on the data bus. Microprocessor reads this data by initiating read command.

### Output port:

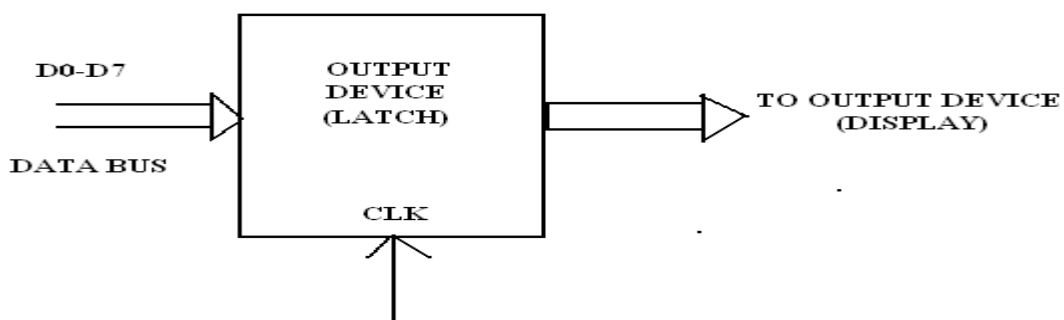

FIG.2 OUTPUT PORT

It is used to send data to the output device such as display from the microprocessor. The simplest form of output port is a latch. The output device is connected to the microprocessor through latch, as shown in the fig.2. When microprocessor wants to send data to the output device is puts the data on the data bus and activates the clock signal of the latch, latching the data from the data bus at the output of latch. It is then available at the output of latch for the output device.

### **Serial and Parallel Transmission:**

In telecommunications, serial transmission is the sequential transmission of signal elements of a group representing a character or other entity of data. Digital serial transmissions are bits sent over a single wire, frequency or optical path sequentially. Because it requires less signal processing and less chance for error than parallel transmission, the transfer rate of each individual path may be faster. This can be used over longer distances as a check digit or parity bit can be sent along it easily.

In telecommunications, parallel transmission is the simultaneous transmission of the signal elements of a character or other entity of data. In digital communications, parallel transmission is the simultaneous transmission of related signal elements over two or more separate paths. Multiple electrical wires are used which can transmit multiple bits simultaneously, which allows for higher data transfer rates than can be achieved with serial transmission. This method is used internally within the computer, for example the internal buses, and sometimes externally for such things as printers, The major issue with this is "skewing" because the wires in parallel data transmission have slightly different properties (not intentionally) so some bits may arrive before others, which may corrupt the message. A parity bit can help to reduce this. However, electrical wire parallel data transmission is therefore less reliable for long distances because corrupt transmissions are far more likely.

### **Interrupt driven I/O:**

In this technique, a CPU automatically executes one of a collection of special routines whenever certain condition exists within a program or a processor system. Example CPU gives response to devices such as keyboard, sensor and other components when they request for service. When the CPU is asked to communicate with devices, it services the devices. Example each time you type a character on a keyboard, a keyboard service routine is called. It transfers the character you typed from the keyboard I/O port into the processor and then to a data buffer in memory.

The interrupt driven I/O technique allows the CPU to execute its main program and only stop to service I/O device when it is told to do so by the I/O system as shown in fig.3. This method provides an external asynchronous input that would inform the processor that it should complete whatever instruction that is currently being executed and fetch a new routine that will service the requesting device. Once this servicing is completed, the processor would resume exactly where it left off.

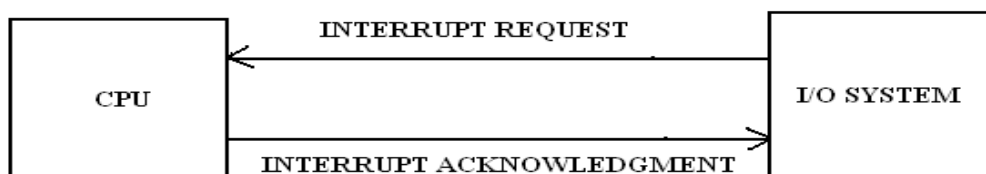

**FIG.3 INTERRUPT DRIVEN I/O**

An analogy to the interrupt concept is in the classroom, where the professor serves as CPU and the students as I/O ports. The classroom scenario for this interrupt analogy will be such that the professor is busy in writing on the blackboard and delivering his lecture.

The student raises his finger when he wants to ask a question (student requesting for service). The professor then completes his sentence and acknowledges student's request by saying "YES" (professor acknowledges the interrupt request). After acknowledgement from the professor, student asks the question and professor gives answer to the question (professor services the interrupt). After that professor continues its remaining lecture from where it was left.

**PIO 8255:**

The parallel input-output port chip 8255 is also called as programmable **peripheral input-output port**. The Intel's 8255 are designed for use with Intel's 8-bit, 16-bit and higher capability microprocessors. It has 24 input/output lines which may be individually programmed in two groups of twelve lines each, or three groups of eight lines.

The two groups of I/O pins are named as Group A and Group B. Each of these two groups contains a subgroup of eight I/O lines called as 8-bit port and another subgroup of four lines or a 4-bit port. Thus Group A contains an 8-bit port A along with a 4-bit port C upper.

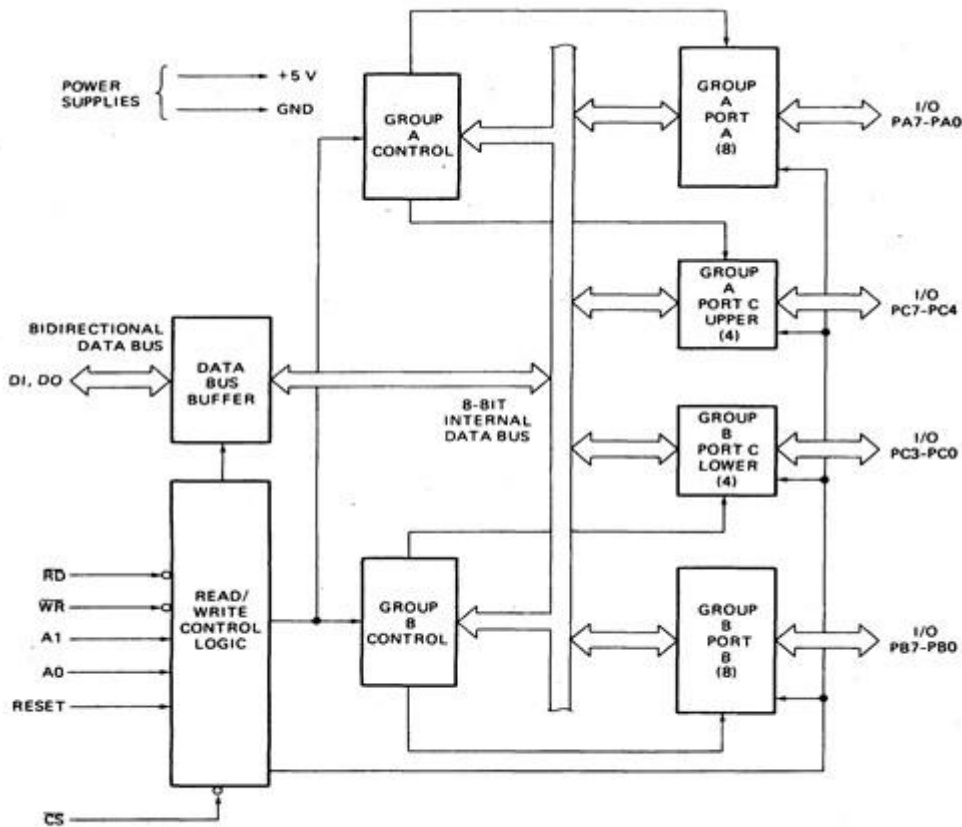

FIGURE Internal block diagram of 8255A programmable parallel port device. (Intel Corporation)

The port A lines are identified by symbols PA0-PA7 while the port C lines are identified as PC4-PC7 similarly. Group B contains an 8-bit port B, containing lines PB0- PB7 and a 4-bit port C with lower bits PC0-PC3. The port C upper and port C lower can be used in combination as an 8-bit port C. Both the port Cs is assigned the same address. Thus one may have either three 8-bit I/O ports or two 8-bit and two 4-bit I/O ports from 8255. All of

these ports can function independently either as input or as output ports. This can be achieved by programming the bits of an internal register of 8255 called as control word register (CWR). The internal block diagram and the pin configuration of 8255 are shown in figs.

The 8-bit data bus buffer is controlled by the read/write control logic. The read/write control logic manages all of the internal and external transfer of both data and control words. RD, WR, A1, A0 and RESET are the inputs, provided by the microprocessor to READ/WRITE control logic of 8255. The 8-bit, 3-state bidirectional buffer is used to interface the 8255 internal data bus with the external system data bus. This buffer receives or transmits data upon the execution of input or output instructions by the microprocessor. The control words or status information is also transferred through the buffer.

### Pin Diagram of 8255A

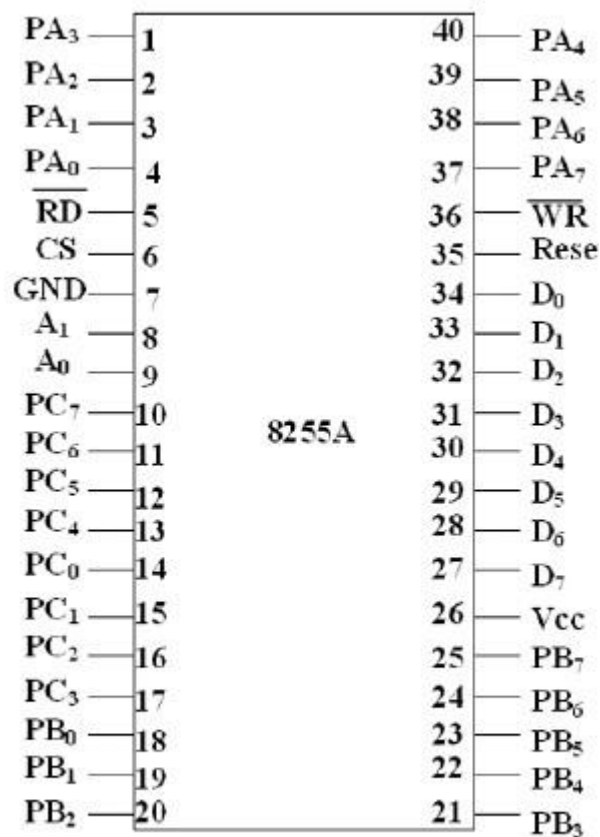

**8255A Pin Configuration**

The pin configuration of 8255 is shown in fig.

- The port A lines are identified by symbols PA0-PA7 while the port C lines are
- Identified as PC4-PC7. Similarly, Group B contains an 8-bit port B, containing lines PB0-PB7 and a 4-bit port C with lower bits PC0- PC3. The port C upper and port C lower can be used in combination as an 8-bit port C.
- Both the port C is assigned the same address. Thus one may have either three 8-bit I/O ports or two 8-bit and two 4-bit ports from 8255. All of these ports can function independently either as input or as output ports. This can be achieved by programming the bits of an internal register of 8255 called as control word

register (CWR).

- The 8-bit data bus buffer is controlled by the read/write control logic. The read/write control logic manages all of the internal and external transfers of both data and control words.
- RD, WR, A1, A0 and RESET are the inputs provided by the microprocessor to the READ/ WRITE control logic of 8255. The 8-bit, 3-state bidirectional buffer is used to interface the 8255 internal data bus with the external system data bus.
- This buffer receives or transmits data upon the execution of input or output instructions by the microprocessor. The control words or status information is also transferred through the buffer.

**The signal description of 8255 is briefly presented as follows:**

- **PA7-PA0:** These are eight port A lines that acts as either latched output or buffered input lines depending upon the control word loaded into the control word register.
- **PC7-PC4:** Upper nibble of port C lines. They may act as either output latches or input buffers lines.
- This port also can be used for generation of handshake lines in mode1 or mode2.
- **PC3-PC0:** These are the lower port C lines; other details are the same as PC7-PC4 lines.
- **PB0-PB7:** These are the eight port B lines which are used as latched output lines or buffered input lines in the same way as port A.
- **RD:** This is the input line driven by the microprocessor and should be low to indicate read operation to 8255.
- **WR:** This is an input line driven by the microprocessor. A low on this line indicates write operation.
- **CS:** This is a chip select line. If this line goes low, it enables the 8255 to respond to RD and WR signals, otherwise RD and WR signal are neglected.
- **D0-D7:** These are the data bus lines those carry data or control word to/from the microprocessor.
- **RESET:** Logic high on this line clears the control word register of 8255. All ports are set as input ports by default after reset.
- **A1-A0:** These are the address input lines and are driven by the microprocessor.
- These lines A1-A0 with RD, WR and CS from the following operations for 8255. These address lines are used for addressing any one of the four registers, i.e. three ports and a control word register as given in table below.

In case of 8086 systems, if the 8255 is to be interfaced with lower order data bus, the A0 and A1 pins of 8255 are connected with A1 and A2 respectively.

$\overline{\text{RD}}$	$\overline{\text{WR}}$	$\overline{\text{CS}}$	A <sub>1</sub>	A <sub>0</sub>	Input (Read) cycle
0	1	0	0	0	Port A to Data bus
0	1	0	0	1	Port B to Data bus
0	1	0	1	0	Port C to Data bus
0	1	0	1	1	CWR to Data bus

$\overline{\text{RD}}$	$\overline{\text{WR}}$	$\overline{\text{CS}}$	A <sub>1</sub>	A <sub>0</sub>	Output (Write) cycle
1	0	0	0	0	Data bus to Port A
1	0	0	0	1	Data bus to Port B
1	0	0	1	0	Data bus to Port C
1	0	0	1	1	Data bus to CWR

$\overline{\text{RD}}$	$\overline{\text{WR}}$	$\overline{\text{CS}}$	A <sub>1</sub>	A <sub>0</sub>	Function
X	X	1	X	X	Data bus tristated
1	1	0	X	X	Data bus tristated

### Control Word Register

### Modes of Operation of 8255

- These are two basic modes of operation of 8255. I/O mode and Bit Set-Reset mode (BSR).
- In I/O mode, the 8255 ports work as programmable I/O ports, while in BSR mode only port C (PC0-PC7) can be used to set or reset its individual port bits.
- Under the I/O mode of operation, further there are three modes of operation of 8255, so as to support different types of applications, mode 0, mode 1 and mode 2.
- **BSR Mode:** In this mode any of the 8-bits of port C can be set or reset depending on D<sub>0</sub> of the control word. The bit to be set or reset is selected by bit select flags D<sub>3</sub>, D<sub>2</sub> and D<sub>1</sub> of the CWR as given in table.

### I/O Modes:

**a) Mode 0 (Basic I/O mode):** This mode is also called as basic input/output Mode. This mode provides simple input and output capabilities using each of the threeports. Data can be simply read from and written to the input and output portsrespectively, after appropriate initialization.

D <sub>3</sub>	D <sub>2</sub>	D <sub>1</sub>	Selected bits of port C
0	0	0	D <sub>0</sub>
0	0	1	D <sub>1</sub>
0	1	0	D <sub>2</sub>
0	1	1	D <sub>3</sub>
1	0	0	D <sub>4</sub>
1	0	1	D <sub>5</sub>
1	1	0	D <sub>6</sub>
1	1	1	D <sub>7</sub>

### BSR Mode : CWR Format

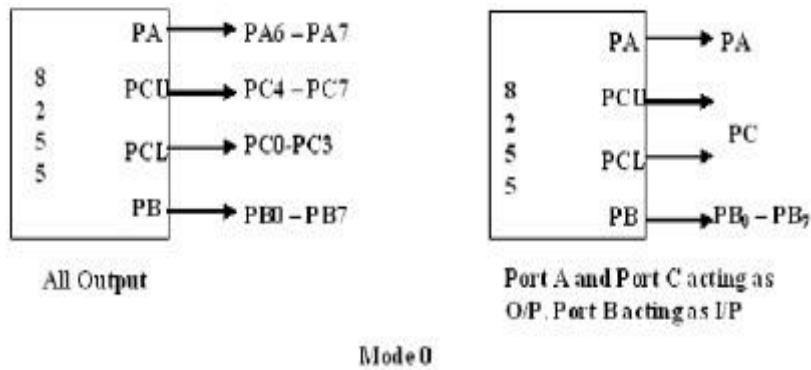

The salient features of this mode are as listed below:

1. Two 8-bit ports (port A and port B) and two 4-bit ports (port C upper and lower) are available. The two 4-bit ports can be combined used as a third 8-bit port.
  2. Any port can be used as an input or output port.
  3. Output ports are latched. Input ports are not latched.
  4. A maximum of four ports are available so that overall 16 I/O configurations are possible.
- All these modes can be selected by programming a register internal to 8255 known as CWR.
  - The control word register has two formats. The first format is valid for I/O modes of operation, i.e. modes 0, mode 1 and mode 2 while the second format is valid for bit set/reset (BSR) mode of operation.

These formats are shown in following fig.

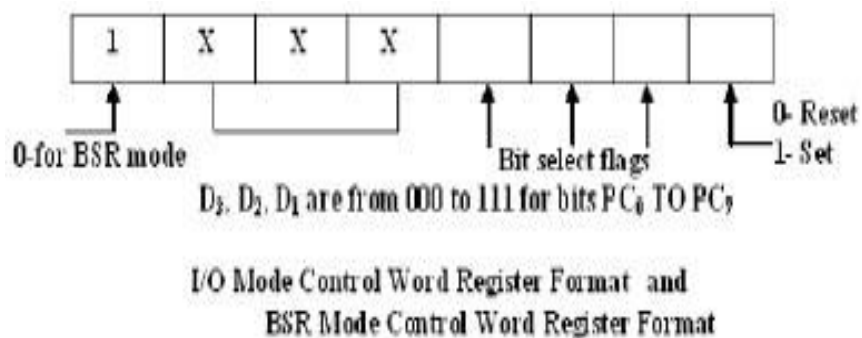

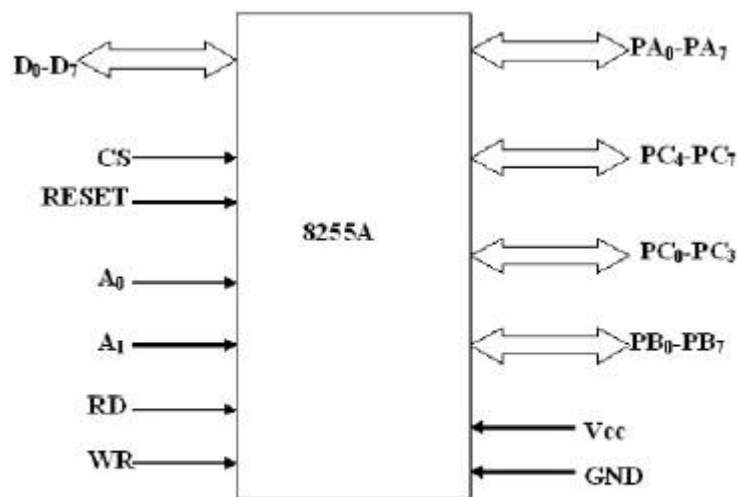

Signals of 8255

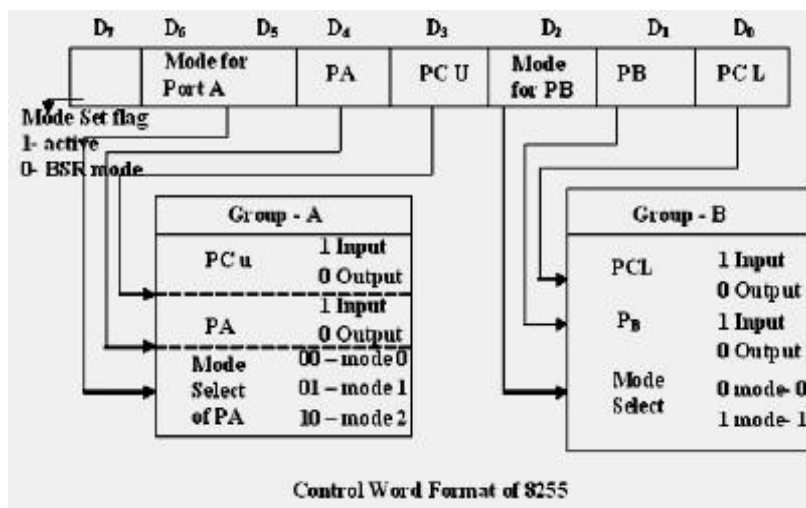

Control Word Format of 8255

**b) Mode 1: (Strobed input/output mode)** in this mode the handshaking control the input and output action of the specified port. Port C lines PC0-PC2, provide strobe or handshake lines for port B. This group which includes port B and PC0-PC2 is called as group B for Strobed data input/output. Port C lines PC3-PC5 provides strobe lines for port A. This group including port A and PC3-PC5 from group A. Thus port C is utilized for generating handshake signals.

The salient features of mode 1 are listed as follows:

1. Two groups – group A and group B are available for strobed data transfer.
2. Each group contains one 8-bit data I/O port and one 4-bit control/data port.
3. The 8-bit data port can be either used as input and output port. The inputs and outputs both are latched.
4. Out of 8-bit port C, PC0-PC2 are used to generate control signals for port B and PC3-PC5 are used to generate control signals for port A. the lines PC6, PC7 may be used as independent data lines.



The control signals for both the groups in input and output modes are explained as follows:

**Input control signal definitions (mode 1):**

- **STB** (Strobe input) – If this lines falls to logic low level, the data available at 8-bit input port is loaded into input latches.
- **IBF** (Input buffer full) – If this signal rises to logic 1, it indicates that data has been loaded into latches, i.e. it works as an acknowledgement. IBF is set by a low on STB and is reset by the rising edge of RD input.
- **INTR** (Interrupt request) – This active high output signal can be used to interrupt the CPU whenever an input device requests the service. INTR is set by a high STB pin and a high at IBF pin. INTE is an internal flag that can be controlled by the bit set/reset mode of either PC4 (INTEA) or PC2 (INTEB) as shown in fig.
- INTR is reset by a falling edge of RD input. Thus an external input device can be request the service of the processor by putting the data on the bus and sending the strobe signal.

**Output control signal definitions (mode 1):**

- **OBF** (Output buffer full) – This status signal, whenever falls to low, indicates that CPU has written data to the specified output port. The OBF flip- flop will beset by a rising edge of WR signal and reset by a low going edge at the ACK input.
- **ACK** (Acknowledge input) – ACK signal acts as an acknowledgement to be given by an output device. ACK signal, whenever low, informs the CPU that the data transferred by the CPU to the output device through the port is received by the output device.
- **INTR** (Interrupt request) – Thus an output signal that can be used to interrupt the CPU when an output device acknowledges the data received from the CPU. INTR is set when ACK, OBF and INTE are 1. It is reset by a

Falling edge on WR input. The INTEA and INTEB flags are controlled by the bit set-reset mode of PC6 and PC2 respectively.

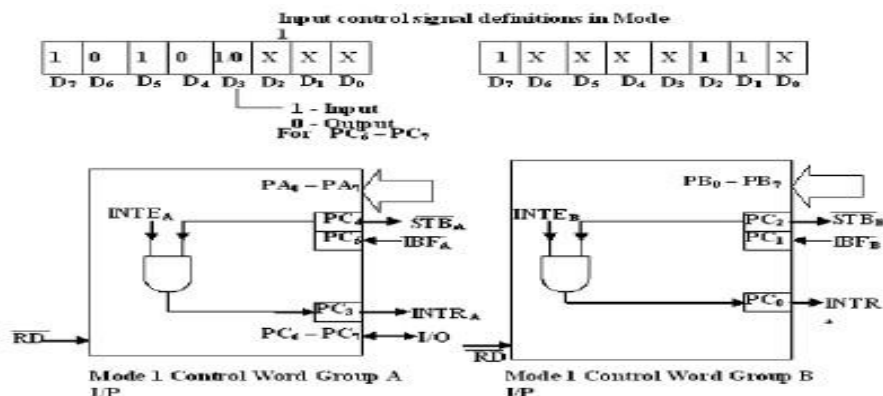

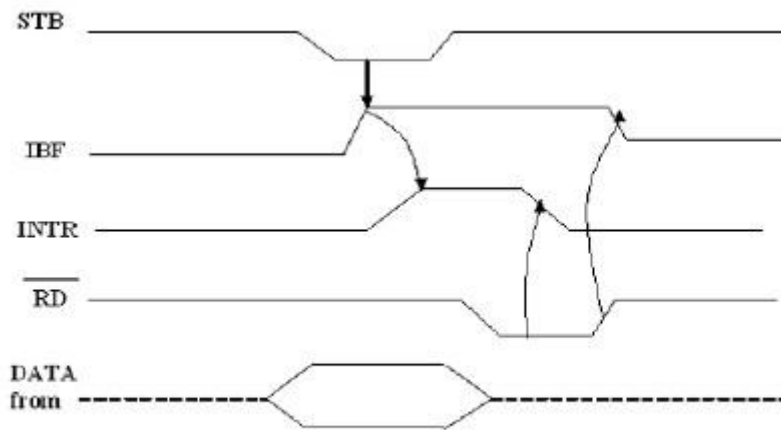

Mode 1 Strobed Input Data Transfer

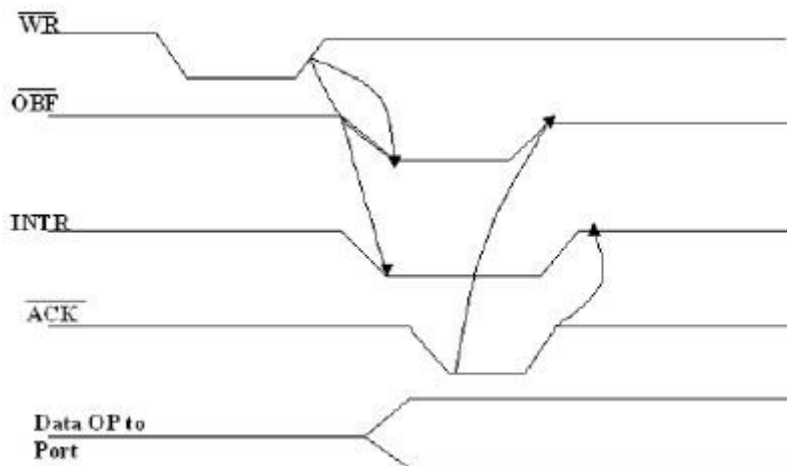

Mode 1 Strobed Data Output

Output control signal definitions Mode 1

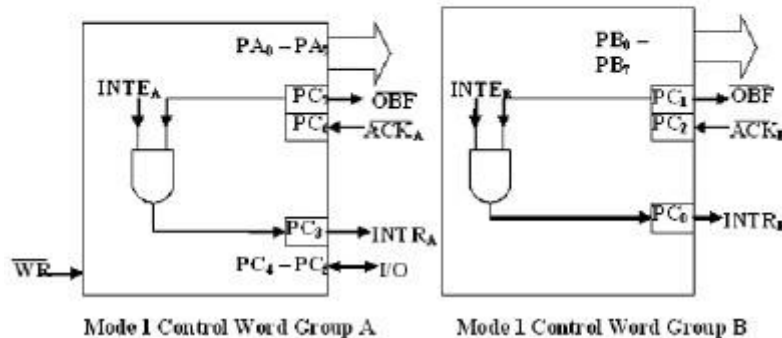
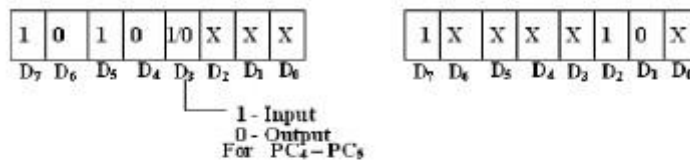

Mode 1 Control Word Group A

Mode 1 Control Word Group B

c) **Mode 2 (Strobed bidirectional I/O):** This mode of operation of 8255 is also called as strobed bidirectional I/O. This mode of operation provides 8255 with additional features for communicating with a peripheral device on an 8-bit data bus. Handshaking signals are provided to maintain proper data flow and synchronization between the data transmitter and receiver. The interrupt generation and other functions are similar to mode 1.

In this mode, 8255 is a bidirectional 8-bit port with handshake signals. The Rd and WR signals decide whether the 8255 is going to operate as an input port or output port.

The Salient features of Mode 2 of 8255 are listed as follows:

1. The single 8-bit port in group A is available.
2. The 8-bit port is bidirectional and additionally a 5-bit control port is available.
3. Three I/O lines are available at port C.( PC2 – PC0 )
4. Inputs and outputs are both latched.
5. The 5-bit control port C (PC3-PC7) is used for generating / accepting handshake signals for the 8-bit data transfer on port A.

#### Control signal definitions in mode 2:

- **INTR** – (Interrupt request) As in mode 1, this control signal is active high and is used to interrupt the microprocessor to ask for transfer of the next data byte to/from it. This signal is used for input (read) as well as output (write) operations.
- **Control Signals for Output operations:**
- **OBF** (Output buffer full) – This signal, when falls to low level, indicates that the CPU has written data to port A.
- **ACK** (Acknowledge) This control input, when falls to logic low level, Acknowledges that the previous data byte is received by the destination and next byte may be sent by the processor. This signal enables the internal tristate buffers to send the next data byte on port A.
- **INTE1** ( A flag associated with OBF ) This can be controlled by bit set/reset mode with PC6.

#### Control signals for input operations:

- **STB** (Strobe input) a low on this line is used to strobe in the data into the input Latches of 8255.
- **IBF** (Input buffer full) when the data is loaded into input buffer, this signal rises to logic „1“. This can be used as an acknowledge that the data has been received by the receiver.
- The waveforms in fig show the operation in Mode 2 for output as well as input port.
- Note: WR must occur before ACK and STB must be activated before RD.

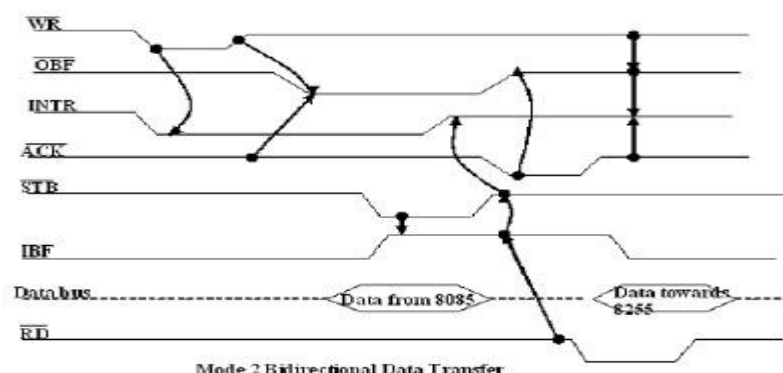

- The following fig shows a schematic diagram containing an 8-bit bidirectional

port, 5-bit control port and the relation of INTR with the control pins. Port B can either be set to Mode 0 or 1 with port A ( Group A ) is in Mode 2.

- Mode 2 is not available for port B. The following fig shows the control word.
- The INTR goes high only if IBF, INTE2, STB and RD go high or OBF,
- INTE1, ACK and WR go high. The port C can be read to know the status of the peripheral device, in terms of the control signals, using the normal I/O instructions.

